



FURNACE BAGS

[TECHNICAL BULLETIN]

HIGH TEMPERATURE FURNACE SEAL

PIPING TECHNOLOGY
& PRODUCTS, INC.
WWW.PIPINGTECH.COM
INFO@MAIL.PIPINGTECH.COM



TECHNICAL BULLETIN: High Temperature Furnace Seal

Piping Technology & Products, Inc.

Objective

Openings between the floor of the furnace and the pipe penetration openings can cause heat energy loss in certain types of furnace applications. A penetration bag type seal is now available to prevent energy loss through the pipe penetrations during the expansion and contraction movement of the pipe through the furnace floor. The use of a furnace seal bag permits movements of the pipe through the furnace floor while providing an airtight closure to prevent heat loss.

Application

PT&P's furnace seal bag works similar to a fabric expansion joint. The bag, consists of multiple layers of flexible, flame and heat resistant, impervious fabric designed to operate from start up to high temperature design conditions. The bag contracts and expands with varying furnace temperatures. The seal bag allows thermal expansion and prevents the loss of heat through the furnace floor which conserves energy and reduces the cost of energy.



Furnace Sealing Bags prior to installation



Furnace Sealing Bag after movement & temperature tests



TECHNICAL BULLETIN: High Temperature Furnace Seal

Piping Technology & Products, Inc.

Components

Stainless steel clamps or band straps connect one end of the pipe that goes through the penetration opening and the other to another sleeve in the furnace floor. A tapered steel coil is installed around the conduit inside the bag to prevent the fabric from collapsing inward during vacuum conditions. PT&P's standard furnace seal bag is nickel reinforced, with a special coating that reduces airborne fibers and increases tensile strength.

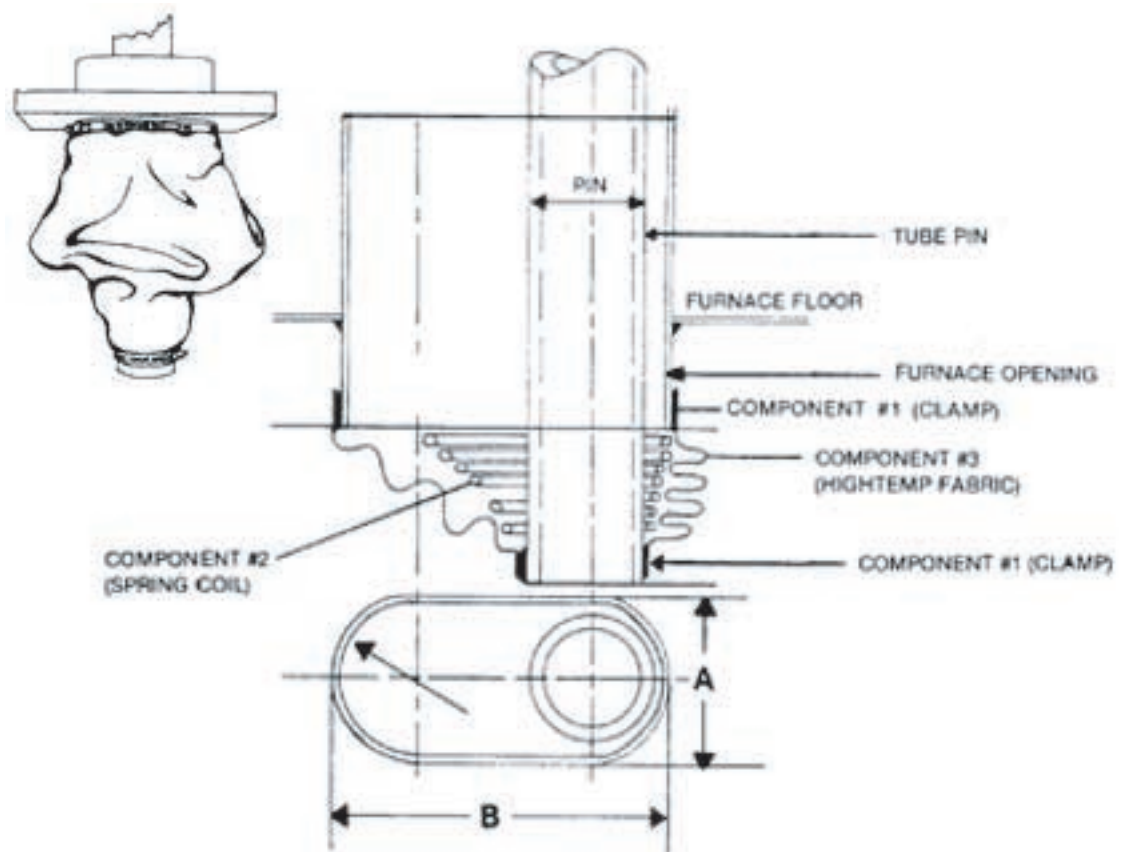

Summary

This type of furnace seal is a cost-effective solution to a problem with potentially high-energy losses. The seal can function through maintenance 'shut-down' cycles and is easily replaced after several years of operation. Furnace bags may also be customized to suit any specifications for unique design needs.